

iglide[®] – clip bearings

Easy installation

Abrasion-resistant

Predictable service life

Custom options possible

Self-lubricating and maintenance-free

Standard range from stock





iglide® clip bearing:
Captured with double flange
▶ Page 694



iglide® Clip2 bearings:
Easy assembly due to lateral slot,
also available with anti-rotation feature
▶ Page 696



iglide® flanged clip bearings:
Press in and fold down
▶ Page 700



iglide® double flanged clip bearings:
Press and plug
▶ Page 701



Custom solution
iglide® snap on:
Snap into place
▶ Page 702

iglide® clip bearings

iglide® clip bearings are designed specifically for fitting shafts through sheet metal. For this reason, the bearings have flanges located on both ends. The bearings are secured in the sheet metal plate on both sides after fitting.

The clip bearings have an angled slot which allows the bearings to be fitted from one side. After fitting, the bearing expands and forms a lining for the hole in the metal plate. The shaft prevents the clip bearing from falling out the housing. Even during linear movement, the bearing cannot slide out of the housing.

- Lateral slot for easy installation
- Self-lubricating and maintenance-free
- Easily adapts to punched holes
- Good abrasion resistance
- Quiet
- For rotating and linear movements

Typical industries and applications

- Automotive industry
- Mechanical engineering
- Jigs and fixtures, etc.



Service life calculation
▶ www.igus.com/iglide-expert



max. +176 °F
min. -40 °F



Material: iglide® M250
6 types
Ø 3–25 mm
more dimensions on request



Ø 3/16 to 1 1/4 inches
more dimensions on request



Available from stock
Detailed information about delivery time online.



iglide® clip bearing

- Easy to fit due to clip-on feature
 - Increased security with the double flange design
 - Good abrasion resistance
- Page 694



iglide® split bearings (Clips2)

- Easy to fit
 - Tolerance compensation with angled slot
 - Low bearing clearance, high precision
- Page 696



iglide® flanged clip bearings

- Easy to fit
 - Pressfit
 - Axial load on both sides
 - Compensation of tolerances of the sheet metal
- Page 700



iglide® double flanged clip bearings

- Easy to fit due to clip-on feature
 - Large flange surfaces
 - Symmetrical flange
 - Remains in place during E-Coat paint process
- Page 701



Special solution

iglide® snap On

- The washer is snapped onto the flanged bearing with undercuts
 - Compensation of axial clearance
 - Secure pre-assembly possible
 - Combination of conductive and non-conductive materials possible
- Page 702

iglide® clip bearings | Application examples



This cutting mechanism is used in the beverage industry. All components meet the requirement of freedom from external lubrication, low cost and reduction of weight



Easy-to-clean and low-cost iglide® clip bearings and iglide® flange bearings are used in a honeycomb processing machine.



By using wear-resistant iglide® clip bearings, the lowering mechanism for radiator mascots on luxury cars could be improved.



The guide rod in this pharmacy printer has been attached using igus® clip bearings.



Rattle-free positioning of seat systems with iglide® plain/clip bearings, e.g. inner/tilt and seat height adjustment.

iglide® clip bearings | Technical data

General properties

The clip bearings have an angled slot which allows the bearings to be fitted from one side. After fitting, the bearing expands and forms a lining for the hole in the metal plate. The shaft prevents the clip bearing from falling out the housing. Even during linear movement, the bearing cannot slide out of the housing. iglide® clip bearings are made from wear resistant material iglide® M250.

iglide® M250 is a plain bearing material with strong wear resistance at average loads. The bearings are self-lubricating and can be used dry. If required the bearings can also be lubricated. The material iglide® M250 is resistant to all common lubricants.

Mechanical properties

The permissible static pressure of iglide® M250 at room temperature is 2,900 psi. Due to the possibility of high tolerances in the housing bore, the clip bearing has a high compressive strength even for punched holes.

For bearing surfaces that are very small, the vibration dampening properties and the resistance to edge loads are especially important.

► iglide® M250, **Page 121**

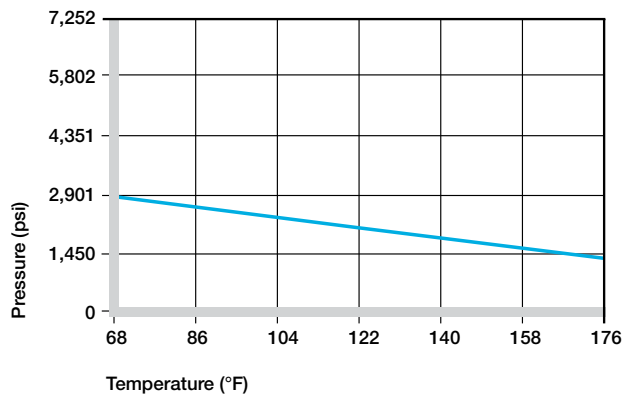

Diagram 01: Recommended maximum surface pressure of as a function of temperature (2,900 psi at +68°F)

Permissible surface speeds

Clip bearings are extremely wear resistant in slow rotating, oscillating, and linear movements. The maximum surface speeds for the different movements are the same as for the material iglide® M250.

With lubrication the permissible speeds can be increased.

► Surface speed, **Page 44**

	Continuous fpm	Short Term fpm
Rotating	157	393
Oscillating	118	275
Linear	492	984

Maximum surface speeds

Temperatures

For operating temperatures up to +176 °F iglide® clip bearings display high wear resistance. Even in the cold, the plain bearings remain elastic and resistant to wear.

► Application temperatures, **Page 49**

iglide® M250	Application temperature
Minimum	-40°F
Max. long term	+176°F
Max. short term	+338°F

Temperature limits

Installation

For installation, the plain bearings are pressed together on the side with the large flange. The angled slot makes the bearing spiral shaped so that it can be placed easily into the metal plate.

The slot also compensates for expansions of the circumference. In this way, a tight clearance is possible with the clip bearings. The bearing clearance is dimensioned in such a way that in a housing bore with a nominal diameter, a shaft made with the same nominal diameter turns easily. The clip bearings should be fitted into a housing with a "H" class tolerance, up to H13. The clip bearing can also rotate within the housing bore.

Diameter d1 [in]	Shaft h9 [in]	Tolerances D11 [in]	Housing H7 [in]
> 0.1181 to 0.2362	0-0.0012	+0.0012 +0.0041	0 +0.0005
> 0.2362 to 0.3937	0-0.0014	+0.0016 +0.0051	0 +0.0006
> 0.3937 to 0.7086	0-0.0017	+0.0020 +0.0063	0 +0.0007
> 0.7086 to 1.1811	0-0.0020	+0.0026 +0.0077	0 +0.0008
> 1.1811 to 1.9685	0-0.0024	+0.0031 +0.0094	0 +0.0010
> 1.9685 to 3.1496	0-0.0029	+0.0000 +0.0000	0 +0.0012

Diameter d1 [mm]	Shaft h9 [mm]	Tolerances D11 [mm]	Housing H7 [mm]
up to 3	0-0.025	+0.020 +0.080	0 +0.010
> 3 to 6	0-0.030	+0.030 +0.105	0 +0.012
> 6 to 10	0-0.036	+0.040 +0.130	0 +0.015
> 10 to 18	0-0.043	+0.050 +0.160	0 +0.018
> 18 to 30	0-0.052	+0.065 +0.195	0 +0.021
> 30 to 50	0-0.062	+0.080 +0.240	0 +0.025
> 50 to 80	0-0.074	+0.100 +0.290	0 +0.030

iglide® Clip bearings | - Product range

Clip bearings for sheet metals – secured with double flange

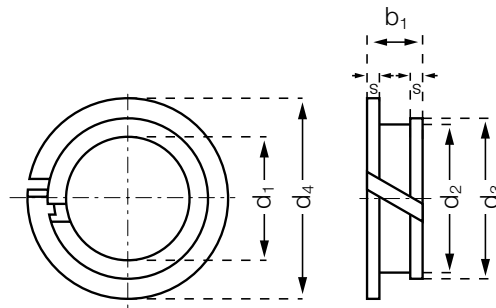

Order key

Type		Dimensions	
M C I - 06 - 01			
iglide® material	Clip bearings	Inch	
		Inner-Ø d1 [mm]	
		Length b1-2s [mm]	



Material:
iglide® M250 ► Page 121

Dimensions [mm]

Part Number	d1 D11 ⁷⁾	d2	d3	d4	s -0.10	b1 + 0.20	ID of Bearing in Housing	Recommended Housing Bore		Recommended Shaft Size	
								Max.	Min.	Max.	Min.
MCI-02-02	1/8	0.1718	3/16	1/4	0.032	0.2000	0.1260	0.1724	0.1718	0.1250	0.1238
MCI-03-01	3/16	0.2343	1/4	5/16	0.032	0.1380	0.1885	0.2414	0.2343	0.1875	0.1865
MCI-03-02	3/16	0.2343	1/4	5/16	0.032	0.2000	0.1885	0.2414	0.2343	0.1875	0.1865
MCI-04-01	1/4	0.3125	11/32	7/16	0.032	0.1380	0.2510	0.3212	0.3125	0.2500	0.2490
MCI-04-02	1/4	0.3125	11/32	7/16	0.032	0.2000	0.2510	0.3212	0.3125	0.2500	0.2490
MCI-05-01	5/16	0.3750	13/32	1/2	0.032	0.1380	0.3135	0.3834	0.3750	0.3125	0.3115
MCI-05-02	5/16	0.3750	13/32	1/2	0.032	0.2000	0.3135	0.3834	0.3750	0.3125	0.3115
MCI-05-03	5/16	0.3750	13/32	1/2	0.032	0.2480	0.3135	0.3834	0.3750	0.3125	0.3115
MCI-06-01	3/8	0.4375	15/32	9/16	0.032	0.1380	0.3760	0.4481	0.4375	0.3750	0.3740
MCI-06-02	3/8	0.4375	15/32	9/16	0.032	0.2000	0.3760	0.4481	0.4375	0.3750	0.3740
MCI-07-01	7/16	0.5000	17/32	5/8	0.032	0.1380	0.4385	0.5106	0.5000	0.4375	0.4365
MCI-07-02	7/16	0.5000	17/32	5/8	0.032	0.2000	0.4385	0.5106	0.5000	0.4375	0.4365
MCI-08-01	1/2	0.5625	19/32	11/16	0.032	0.1380	0.5010	0.5731	0.5625	0.5000	0.4990
MCI-08-02	1/2	0.5625	19/32	11/16	0.032	0.2000	0.5010	0.5731	0.5625	0.5000	0.4990
MCI-08-03	1/2	0.5625	19/32	11/16	0.032	0.2480	0.5010	0.5731	0.5625	0.5000	0.4990
MCI-10-01	5/8	0.6875	23/32	7/8	0.032	0.1380	0.6260	0.6981	0.6875	0.6250	0.6240
MCI-10-02	5/8	0.6875	23/32	7/8	0.032	0.2000	0.6260	0.6981	0.6875	0.6250	0.6240
MCI-12-01	3/4	0.8125	27/32	1	0.032	0.1380	0.7510	0.8255	0.8125	0.7500	0.7490
MCI-12-02	3/4	0.8125	27/32	1	0.032	0.2000	0.7510	0.8255	0.8125	0.7500	0.7490
MCI-16-02	1	1.0755	1 1/8	1 1/4	0.032	0.2000	1.0010	1.0763	1.0755	1.0000	0.9980
MCI-20-02	1 1/4	1.3280	1 3/8	1 17/32	0.0390	0.2180	1.2530	1.3290	1.3280	1.2500	1.2476

⁷⁾ d1 value is measured with a plug gauge after fitting into a reference housing d2 (+0.0002"). Please see D11 tolerances table
► Page 693

iglide® Clip bearings | Product range

Clip bearings for sheet metals – secured with double flange

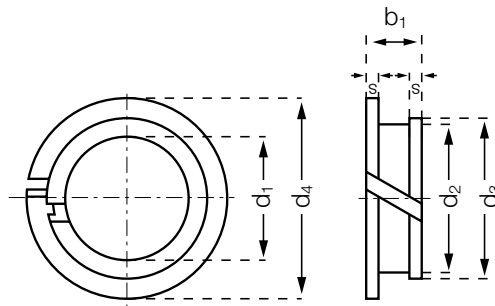

Order key

Type		Dimensions	
M C M-06-015			
iglide® material	Clip bearings	Metric	
		Inner-Ø d1 [mm]	Length b1-2s [mm]



Material:
iglide® M250 ▶ Page 121

Dimensions [mm]

Part Number	d1 D11 ⁷⁾	d2	d3	d4	s	b1	ID of Bearing in Housing	Recommended Housing Bore		Recommended Shaft Size	
								Max.	Min.	Max.	Min.
MCM-03-02	3	4.2	4.8	6	0.6	3.2	3.025	4.380	4.200	3.000	2.975
MCM-03-03	3	4.2	4.8	6	0.6	4.2	3.025	4.380	4.200	3.000	2.975
MCM-04-02	4	5.2	5.9	7	0.6	3.2	4.025	5.380	5.200	4.000	3.975
MCM-04-03	4	5.2	5.9	7	0.6	4.2	4.025	5.380	5.200	4.000	3.975
MCM-05-02	5	6.2	6.8	8	0.6	3.2	5.025	6.420	6.200	5.000	4.975
MCM-05-03	5	6.2	6.8	8	0.6	4.2	5.025	6.420	6.200	5.000	4.975
MCM-06-015	6	7.2	7.8	11	0.6	2.7	6.025	7.420	7.200	6.000	5.975
MCM-06-02	6	7.2	7.8	11	0.6	3.2	6.025	7.420	7.200	6.000	5.975
MCM-06-03	6	7.2	7.8	11	0.6	4.2	6.025	7.420	7.200	6.000	5.975
MCM-06-04	6	7.2	7.8	11	0.6	5.2	6.025	7.420	7.200	6.000	5.975
MCM-07-03	7	9.0	9.8	13	0.8	4.6	7.025	9.220	9.000	7.000	6.975
MCM-08-02	8	9.6	10.4	13	0.8	3.6	8.025	9.820	9.600	8.000	7.975
MCM-08-03	8	9.6	10.4	13	0.8	4.6	8.025	9.820	9.600	8.000	7.975
MCM-08-04	8	9.6	13.0	10.4	0.8	5.6	8.025	9.820	9.600	8.000	7.975
MCM-09-02	9	10.6	11.4	14	0.8	3.6	9.025	10.870	10.600	9.000	8.975
MCM-10-02	10	11.6	12.4	15	0.8	3.6	10.025	11.870	11.600	10.000	9.975
MCM-10-025	10	11.6	12.4	15	0.8	4.1	10.025	11.870	11.600	10.000	9.975
MCM-10-03	10	11.6	12.4	15	0.8	4.6	10.025	11.870	11.600	10.000	9.975
MCM-10-04	10	11.6	12.4	15	0.8	5.6	10.025	11.870	11.600	10.000	9.975
MCM-10-08	10	11.6	12.4	15	0.8	9.6	10.025	11.870	11.600	10.000	9.975
MCM-12-018	12	13.6	14.4	17	0.8	3.4	12.025	13.870	13.600	12.000	11.975
MCM-12-02	12	13.6	14.4	17	0.8	3.6	12.025	13.870	13.600	12.000	11.975
MCM-12-025	12	13.6	14.4	17	0.8	4.4	12.025	13.870	13.600	12.000	11.975
MCM-12-03	12	13.6	14.4	17	0.8	4.6	12.025	13.870	13.600	12.000	11.975
MCM-12-035	12	13.6	14.4	17	0.8	5.1	12.025	13.870	13.600	12.000	11.975
MCM-12-04	12	13.6	14.4	17	0.8	5.6	12.025	13.870	13.600	12.000	11.975
MCM-12-045	12	13.6	14.4	17	0.8	6.4	12.025	13.870	13.600	12.000	11.975
MCM-14-03	14	15.6	16.4	19	0.8	4.6	14.025	15.870	15.600	14.000	13.975
MCM-16-02	16	17.6	18.4	21	0.8	3.6	16.025	17.870	17.600	16.000	15.975
MCM-16-03	16	17.6	18.4	21	0.8	4.6	16.025	17.870	17.600	16.000	15.975
MCM-18-02	18	20	21	23	0.8	4	18.025	20.330	20.000	18.000	17.975
MCM-18-03	18	20	21	23	1.0	5.0	18.025	20.330	20.000	18.000	17.975
MCM-20-03	20	22	23	25	1.0	5.0	20.025	22.330	22.000	20.000	19.975
MCM-25-03	25	27	28	30	1.0	5.0	25.025	27.330	27.000	25.000	24.975
MCM-25-06	25	27	28	30	1	8	25.025	27.330	27.000	25.000	24.975

⁷⁾ d1 value is measured with a plug gauge after fitting into a reference housing d2 (+0.005). Please see D11 tolerances table

▶ Page 693

iglide® Clip bearings | - Product range

Split bearings (Clip2) – easy assembly

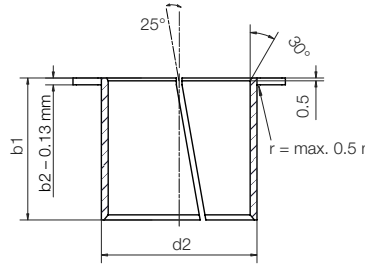
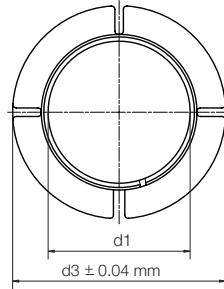

Order key

Type	Dimensions
M Y I - 04 - 04	
iglide® material	
Clip2	
Inch	
Inner-Ø d1 [inch] Based on 1/16"	
Length b1 [mm] Based on 1/16"	



Material:
iglide® M250 ► Page 121
with anti-rotation feature ► Page 698

Dimensions [mm]

Part Number	d1	d2	d3	b1	b2	W	Recommended Housing Bore		Recommended Shaft Size	
							Max.	Min.	Max.	Min.
MYI-03-03	3/16	0.2339	5/16	3/16	0.0252	25°	0.2351	0.2339	0.1875	0.1865
MYI-04-04	1/4	0.2965	13/32	1/4	0.0252	25°	0.2979	0.2965	0.2500	0.2490
MYI-05-05	5/16	0.3744	1/2	5/16	0.0299	25°	0.3758	0.3744	0.3125	0.3115
MYI-05-07	5/16	0.3744	1/2	7/16	0.0299	25°	0.3758	0.3744	0.3125	0.3115
MYI-05-10	5/16	0.3744	1/2	5/8	0.0299	25°	0.3758	0.3744	0.3125	0.3115
MYI-06-06	3/8	0.4370	19/32	3/8	0.0299	25°	0.4387	0.4370	0.3750	0.3740
MYI-06-11	3/8	0.4370	19/32	11/16	0.0299	25°	0.4387	0.4370	0.3750	0.3740
MYI-07-07	7/16	0.4996	21/32	7/16	0.0299	25°	0.5013	0.4996	0.4375	0.4365
MYI-08-03	1/2	0.5618	3/4	3/16	0.0299	25°	0.5635	0.5618	0.5000	0.4990
MYI-08-06	1/2	0.5618	3/4	3/8	0.0299	25°	0.5635	0.5618	0.5000	0.4990
MYI-08-08	1/2	0.5618	3/4	1/2	0.0299	25°	0.5635	0.5618	0.5000	0.4990
MYI-10-07	5/8	0.6870	15/16	7/16	0.0299	25°	0.6887	0.6870	0.6250	0.6240
MYI-10-10	5/8	0.6870	15/16	5/8	0.0299	25°	0.6887	0.6870	0.6250	0.6240
MYI-10-14	5/8	0.6870	15/16	7/8	0.0299	25°	0.6887	0.6870	0.6250	0.6240
MYI-10-18	5/8	0.6870	15/16	1 1/8	0.0299	25°	0.6887	0.6870	0.6250	0.6240
MYI-12-12	3/4	0.8118	1 1/8	3/4	0.0299	25°	0.8139	0.8118	0.7500	0.7490
MYI-12-18	3/4	0.8118	1 1/8	1 1/8	0.0299	25°	0.8139	0.8118	0.7500	0.7490
MYI-14-7.5	7/8	0.9370	1 5/16	15/32	0.0299	25°	0.9391	0.9370	0.8750	0.8740
MYI-14-14	7/8	0.9370	1 5/16	7/8	0.0299	25°	0.9391	0.9370	0.8750	0.8740
MYI-16-10	1	1.0933	1 1/2	5/8	0.0449	25°	1.0954	1.0933	1.0000	0.9985
MYI-16-14	1	1.0933	1 1/2	7/8	0.0449	25°	1.0954	1.0933	1.0000	0.9985
MYI-16-16	1	1.0933	1 1/2	1	0.0449	25°	1.0954	1.0933	1.0000	0.9985
MYI-18-18	1 1/8	1.2185	1 11/16	1 1/8	0.0449	25°	1.2205	1.2185	1.1250	1.1230

⁷⁾ d1 value is measured with a plug gauge after fitting into a reference housing d2 (+0.005)

⁹⁾ Recommended housing bore tolerance: H9

iglide® Clip bearings | Product range

Split bearings (Clip2) – easy assembly

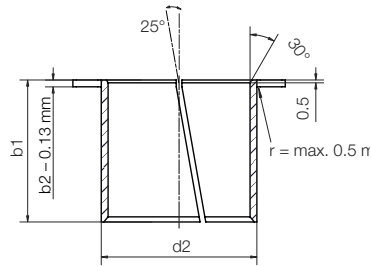
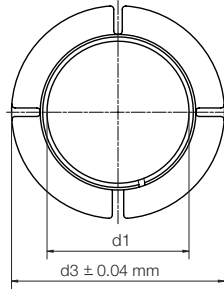

Order key

Type	Dimensions
M Y M - 04 - 04	
iglide® material	
Clip2	
Metric	
Inner-Ø d1 [mm]	
Total Length b1 [mm]	



Material:
iglide® M250 ▶ Page 121
with anti-rotation feature ▶ Page 698

Dimensions [mm]

Part Number	d1	d1 tolerance ⁷⁾	d2 ⁹⁾	d3	b1	b2	Recommended Housing Bore		Recommended Shaft Size	
							Max.	Min.	Max.	Min.
MYM-04-04	4	+0.025 +0.075	5.2	7.0	4.0	0.6	5.230	5.200	4.000	3.975
MYM-05-05	5	+0.025 +0.075	6.2	8.0	5.0	0.6	6.236	6.200	5.000	4.975
MYM-06-06	6	+0.025 +0.075	7.2	9.5	6.0	0.6	7.236	7.200	6.000	5.975
MYM-08-08	8	+0.025 +0.075	9.6	12.0	8.0	0.8	9.636	9.600	8.000	7.975
MYM-10-10	10	+0.025 +0.075	11.6	15.0	10.0	0.8	11.643	11.600	10.000	9.975
MYM-12-06	12	+0.025 +0.075	13.6	18.0	6.0	0.8	13.643	13.600	12.000	11.975
MYM-12-12	12	+0.025 +0.075	13.6	18.0	12.0	0.8	13.643	13.600	12.000	11.975
MYM-14-14	14	+0.025 +0.075	15.6	21.0	14.0	0.8	15.643	15.600	14.000	13.975
MYM-16-16	16	+0.025 +0.075	17.6	24.0	16.0	0.8	17.643	17.600	16.000	15.975
MYM-20-16	20	+0.025 +0.075	21.6	30.0	16.0	0.8	21.652	21.600	20.000	19.948
MYM-20-20	20	+0.025 +0.075	21.6	30.0	20.0	0.8	21.652	21.600	20.000	19.948
MYM-25-25	25	+0.025 +0.075	27.4	37.5	25.0	1.2	27.348	27.400	25.000	24.948

⁷⁾ d1 value is measured with a plug gauge after fitting into a reference housing d2 (+0.005)

⁹⁾ Recommended housing bore tolerance: H9

iglide® Clip bearings | - Product range

Split bearing with anti-rotation feature

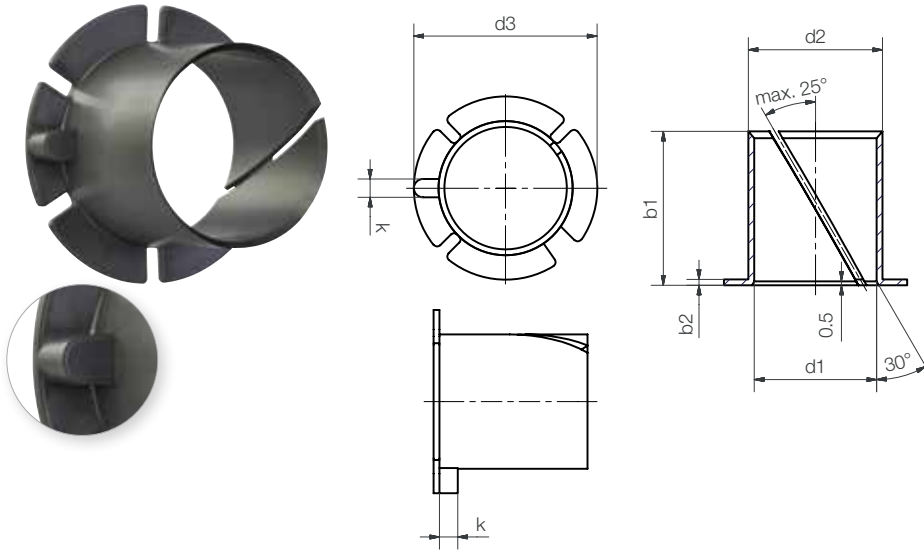

Order key

Type		Dimensions		Option
M Y I - 04 - 04				K
iglide® material	Clip2	Inch	Inner-Ø d1 [inch] Based on 1/16"	Length b1 [mm] Based on 1/16"
				Anti rotation feature



Material:
iglide® M250 ► Page 121

Dimensions [mm]

Part Number	d1	d2	d3	b1	b2	W	k	Recommended Housing Bore		Recommended Shaft Size	
								Max.	Min.	Max.	Min.
MYI-04-04K	1/4	0.2965	13/32	1/4	0.0252	25°	1/16	0.2979	0.2965	0.2500	0.2490
MYI-05-05K	5/16	0.3744	1/2	5/16	0.0299	25°	3/32	0.3758	0.3744	0.3125	0.3115
MYI-05-07K	5/16	0.3744	1/2	7/16	0.0299	25°	3/32	0.3758	0.3744	0.3125	0.3115
MYI-06-06K	3/8	0.4370	19/32	3/8	0.0299	25°	3/32	0.4387	0.4370	0.3750	0.3740
MYI-07-07K	7/16	0.4996	21/32	7/16	0.0299	25°	3/32	0.5013	0.4996	0.4375	0.4365
MYI-08-06K	1/2	0.5618	3/4	3/8	0.0299	25°	3/32	0.5635	0.5618	0.5000	0.4990
MYI-08-08K	1/2	0.5618	3/4	1/2	0.0299	25°	3/32	0.5635	0.5618	0.5000	0.4990
MYI-10-07K	5/8	0.6870	15/16	7/16	0.0299	25°	1/8	0.6887	0.6870	0.6250	0.6240
MYI-10-10K	5/8	0.6870	15/16	5/8	0.0299	25°	1/8	0.6887	0.6870	0.6250	0.6240
MYI-10-18K	5/8	0.6870	15/16	1 1/8	0.0299	25°	1/8	0.6887	0.6870	0.6250	0.6240
MYI-12-12K	3/4	0.8118	1 1/8	3/4	0.0299	25°	1/8	0.8139	0.8118	0.7500	0.7490
MYI-12-18K	3/4	0.8118	1 1/8	1 1/8	0.0299	25°	1/8	0.8139	0.8118	0.7500	0.7490
MYI-14-7.5K	7/8	0.9370	1 5/16	15/32	0.0299	25°	1/8	0.9391	0.9370	0.8750	0.8740
MYI-14-14K	7/8	0.9370	1 5/16	7/8	0.0299	25°	1/8	0.9391	0.9370	0.8750	0.8740
MYI-16-10K	1	1.0933	1 1/2	5/8	0.0449	25°	5/32	1.0954	1.0933	1.0000	0.9985
MYI-16-14K	1	1.0933	1 1/2	7/8	0.0449	25°	5/32	1.0954	1.0933	1.0000	0.9985
MYI-16-16K	1	1.0933	1 1/2	1	0.0449	25°	5/32	1.0954	1.0933	1.0000	0.9985
MYI-18-18K	1 1/8	1.2185	1 11/16	1 1/8	0.0449	25°	5/32	1.2205	1.2185	1.1250	1.1230
MYI-24-24K	1 1/2	1.6245	2 1/4	1 1/2	0.0591	25°	3/16	1.6265	1.6245	1.5000	1.4980

⁷⁾ d1 value is measured with a plug gauge after fitting into a reference housing d2 (+0.0002")

⁹⁾ Recommended housing bore tolerance: H9

iglide® Clip bearings | Product range

Flanged bearings – press in and fold down

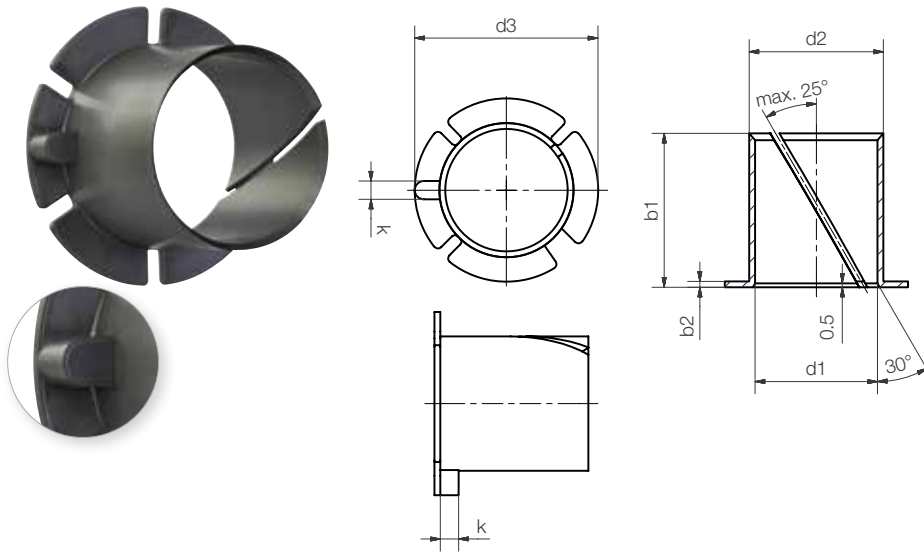

Order key

Type	Dimensions	Option
M Y M - 04 - 04		K
iglide® material	Clip2	Metric
Inner-Ø d1 [mm]	Length b1 [mm]	Anti rotation feature

i Material: iglide® M250 ► Page 121

Dimensions [mm]

Part Number	d1	d2	d3	b1	b2	W	k	Recommended Housing Bore		Recommended Shaft Size	
								Max.	Min.	Max.	Min.
MYM-04-04K	4	5.2	7.0	4.0	0.6	25°	1.0	5.230	5.200	4.000	3.975
MYM-05-05K	5	6.2	8.0	5.0	0.6	25°	1.0	6.236	6.200	5.000	4.975
MYM-06-06K	6	7.2	9.5	6.0	0.6	25°	1.5	7.236	7.200	6.000	5.975
MYM-08-08K	8	9.6	12.0	8.0	0.8	25°	1.5	9.636	9.600	8.000	7.975
MYM-10-10K	10	11.6	15.0	10.0	0.8	25°	2.0	11.643	11.600	10.000	9.975
MYM-14-14K	14	15.6	21.0	14.0	0.8	25°	3.0	15.643	15.600	14.000	13.975

⁷⁾ d1 value is measured with a plug gauge after fitting into a reference housing d2 (+0.005)

⁹⁾ Recommended housing bore tolerance: H9

iglide® Clip bearings | - Product range

Flanged bearings – press in and fold down

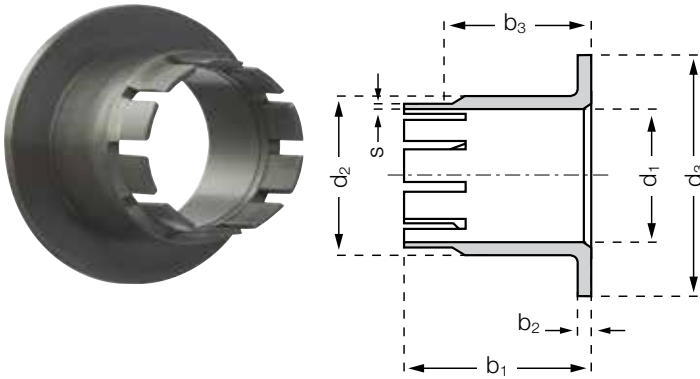

Order key

Type		Dimensions		
M	K	M-10	12	10
iglide® material	Type (Form K)	Metric	Inner-Ø d1 [mm]	Outer-Ø d2 [mm]
Sheet metal thickness [mm]				

i Material:
iglide® M250 ▶ Page 121

Sample dimension [mm]

Part No.	d1	d1 Tolerance E10	d2	d3	b1	b2	b3	s
				d13	h13	-0.14	+0.1/+0.7	±0.1
MKM-1012-10	10	+0.025 +0.083	12	18	14	1	10	0.4

³⁾ After pressfit. Testing methods ▶ Page 57

Assembly:

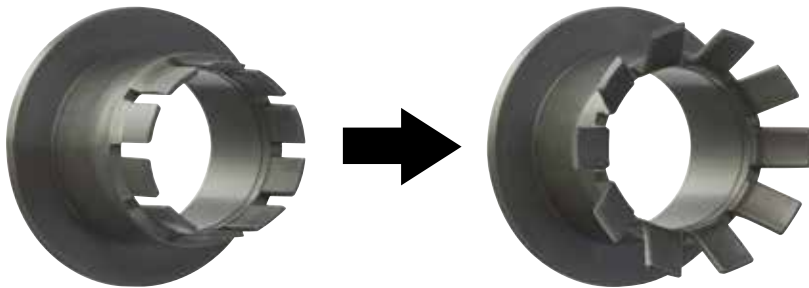

Press in, fold down, ready: axial load on both sides



i Please contact us if you need a custom-made bearing for your application. We will help you with your design, drawing on the experience that we have with a large number of custom bearing solutions.

Double flange bearing – press and plug

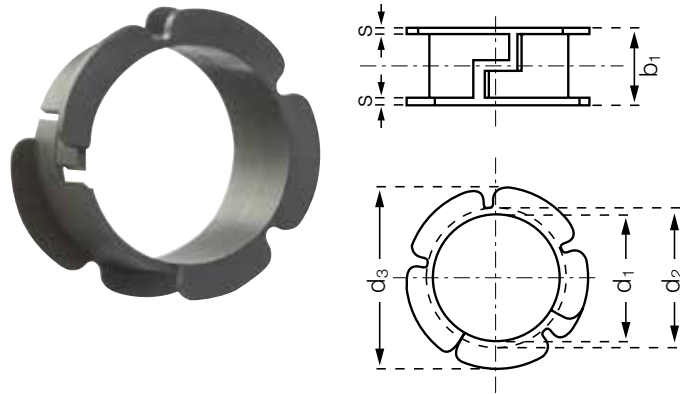

Order key

Type		Dimensions		
M D M - 12 13 - 06				
iglide® material	Type (Form D)	Metric	Inner-Ø d1 [mm]	Outer-Ø d2 [mm]
				Sheet metal thickness [mm]

i Material:
iglide® M250 ► Page 121

Sample dimension [mm]

Part No.	d1	d1 Tolerance ^{®)}	d2	d3	b1	s
MDM-1213-06	12	+0.050 +0.160	13	16.5	7	0.5

^{®)} d1 value is measured with a pin gauge after fitting into a reference housing d2 (+0.005)

Assembly:



i Please contact us if you need a custom-made bearing for your application. We will help you with your design, drawing on the experience that we have with a large number of custom bearing solutions. bearing solutions.

iglide® Clip bearings - Custom solution

iglide® Snap-On: connect and snap into place



i Material:
iglide® M250 ► Page 121

The solution for all applications in stamped sheet metal retainers

iglide® Snap-On are frequently used in seat and convertible top systems and multi-joint hinges. iglide® clip-on bearings allow for captured assembly even in punched sheet metal / steering arms with limited fine blanking content.

- Compensation of axial clearance
- Pre-assembly possible
- Electrically conductive materials are available
- Pressure-resistant materials up to 11,600 psi

The snap-on bearings can also be produced from electrically conducting and other materials for e-coating purposes.

i **Assembly:**
The washer is snapped onto the flange bushing with undercuts.



i Please contact us if you need a custom-made bearing for your application. We will help you with your design, drawing on the experience that we have with a large number of custom bearing solutions. bearing solutions.