

## Custom-made piston rings

In addition to the stock range of iglidur® J piston rings, you can also select your required piston ring on the basis of the entire iglidur® bearing range.  
Use the entire iglidur® plain bearing range and choose the material best suited to your application. Your piston ring will be delivered within 10 days – to your requirements.

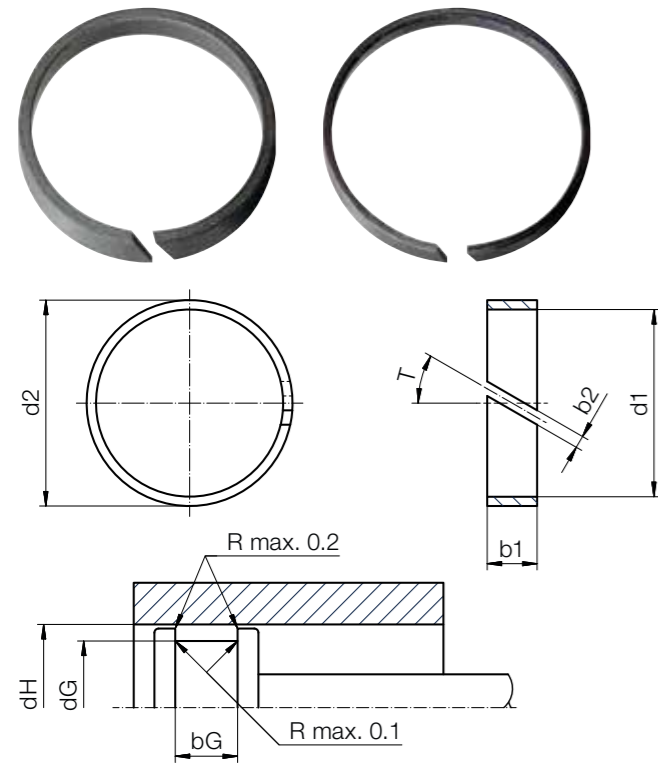

### Order key

Type Dimensions [mm]

PR M--

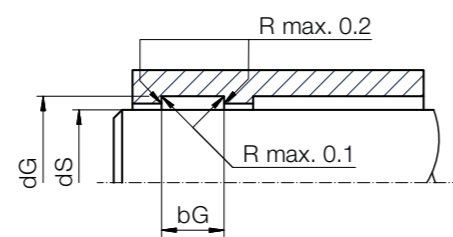
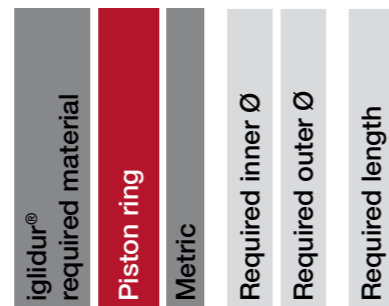

### Installation recommendation for piston

Dimensions [mm]	dG (h tolerance)	dH (H tolerance)	bG
Nominal size	dG = d1	dH = d2	bG = b1 + 0.2

### Installation recommendation for housing

Dimensions [mm]	dS (h tolerance)	dG (H tolerance)	bG
Nominal size	dS = d1	dG = d2	bG = b1 + 0.2

- !** Our material recommendations for special requirements:
- iglidur® A181: FDA-compliant ▶ Page 401
  - iglidur® J350: > +90°C ▶ Page 199
  - iglidur® H1: Temperatures up to +200°C ▶ Page 333

- Q** iglidur® piston rings product finder  
Material selection and individual dimensions made easy. With just a few clicks, the piston ring finder can find the optimum iglidur® material and select the appropriate dimensions from the standard catalogue range in order to define a piston ring in a customised width.  
▶ [www.igus.eu/pistonring-finder](http://www.igus.eu/pistonring-finder)

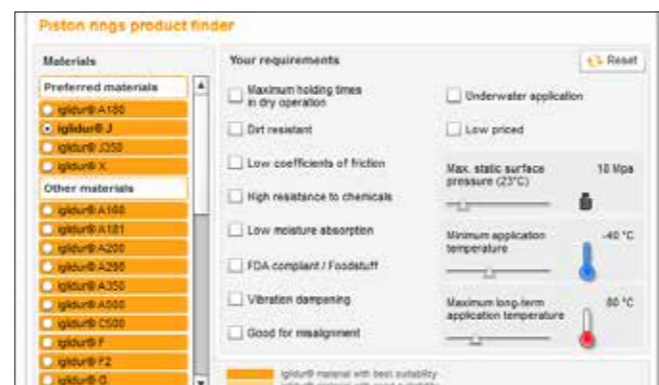

**i** In addition to mechanical processing of existing iglidur® plain bearings to piston rings, we also develop custom-made piston ring solutions for your volume requirements. Talk to us! We will support you with your design and create an appropriate proposal.

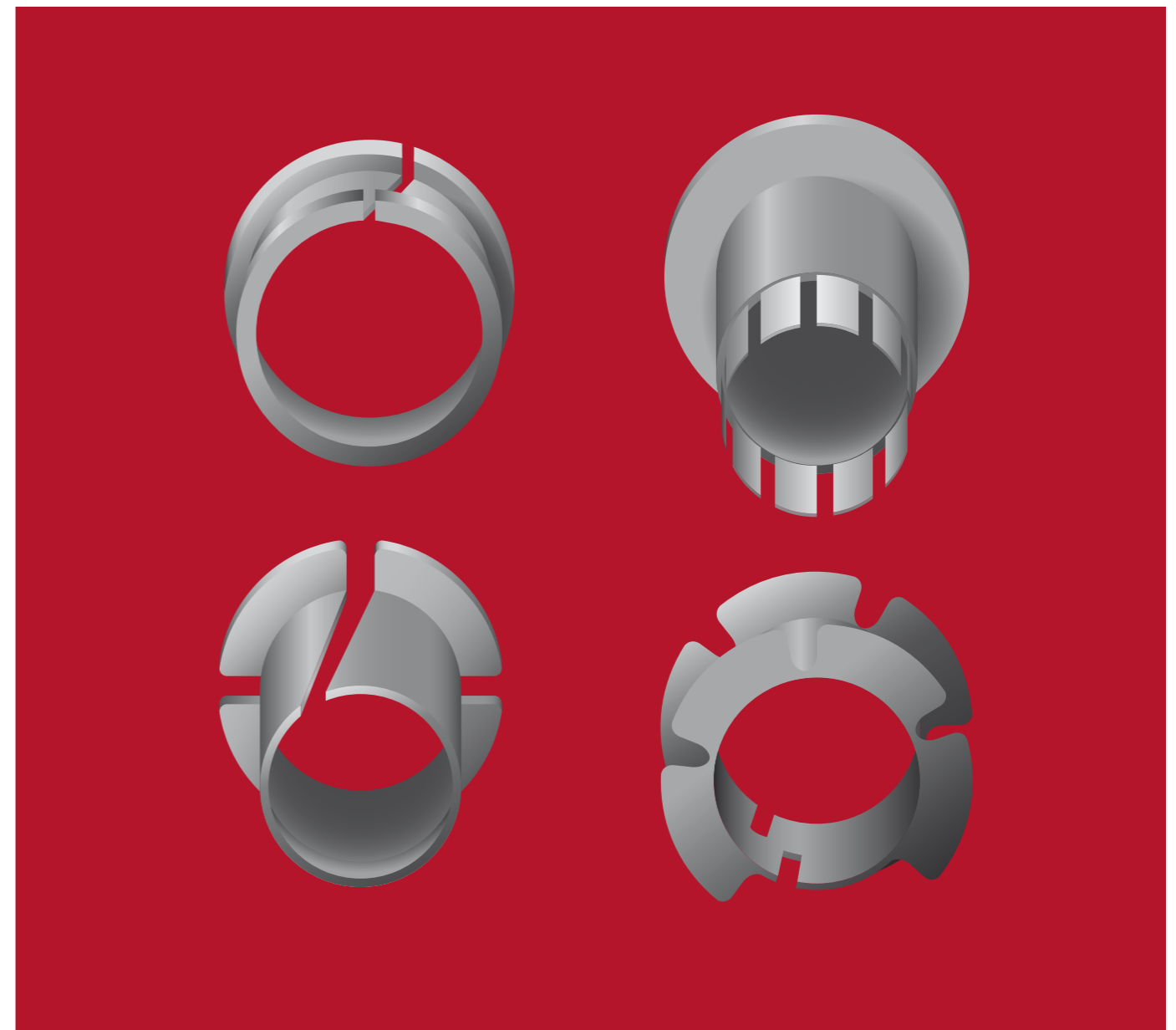

## iglidur® – clip bearings

Easy installation

Abrasion-resistant

Predictable service life

Custom versions possible

Lubrication and maintenance-free

Standard range from stock





**iglidur® clip bearings:**  
Captive with double flange  
► From page 590



**iglidur® split bearings:**  
Easy assembly due to lateral slot,  
also with anti-rotation feature  
► From page 592



**iglidur® flanged bearings:**  
Press in and fold down  
► From page 594



**iglidur® double flange bearings:**  
Press and plug  
► From page 595



**Special solution**  
**iglidur® Clip On:**  
Join and snap into place  
► From page 596

## iglidur® clip bearings for fitting shafts

iglidur® clip bearings are designed specifically for fitting shafts through sheet metal. For this reason, the bearings have flanges located on both ends. The plain bearings are secured in the sheet metal plate on both sides after fitting.

The clip bearings have an angled slot which allows them to be fitted from one side. After fitting, the bearing expands and forms a lining for the hole in the metal plate. The shaft prevents the clip bearing from falling out the housing. Even during linear movement, the plain bearing cannot slide out.

- Lateral slot for easy installation
- Lubrication and maintenance-free
- Good adaptability to punched holes
- Abrasion-resistant
- Quiet
- For rotating and linear movements

### Typical application areas

- Automotive industry
- Mechanical engineering
- Jig construction

**Material: iglidur® M250**  
**6 types**  
Ø 3–25mm

More dimensions upon request

**Imperial dimensions available**  
► From page 1603



### iglidur® clip bearings

- Easy to fit due to clip-on feature
  - Increased security with the double flange design
  - Abrasion-resistant
- From page 590



### iglidur® split bearings (clips2)

- Easy to fit
  - Tolerance compensation with angled slot
  - Low bearing clearance, high precision
- From page 592



### iglidur® flanged bearings

- Easy installation
  - Press-fit
  - Axial load on both sides
  - Compensation of tolerances of the sheet metal
- From page 594



### iglidur® double flange bearings

- Easy to fit due to clip-on feature
  - Large flange surfaces
  - Two identical large flange surfaces
- From page 595



### Special solution iglidur® Clip On

- The disc is snapped onto the flanged bearing with undercuts
  - Compensation of axial clearance
  - Captive pre-assembly possible
  - Combination of conductive and non-conductive materials
- From page 596

**Available from stock**  
Detailed information about delivery time online.

**Max. +80°C**  
**Min. -40°C**



This cutting mechanism is used in the beverage industry. All used components meet the requirement of freedom from lubrication with low weight and low cost.



Easy-to-clean and cost-effective iglidur® flanged bearings and clip bearings are used in a honeycomb.



By using wear-resistant iglidur® clip bearings, the lowering mechanism for radiator mascots on luxury cars could be improved.



The guide rod in this pharmacy printer has been attached using iglidur® clip bearings.



Rattle-free positioning of seat systems with iglidur® clip bearings, e.g. inner/tilt and seat height adjustment.

### General properties

The clip bearings have an angled slot which allows the bearings to be fitted from one side. After fitting, the bearing expands and forms a lining for the hole in the metal plate. The shaft prevents the clip bearing from falling out the housing. Even during linear movement, the bearing cannot slide out. iglidur® clip bearings are made from wear-resistant material iglidur® M250.

iglidur® M250 is a plain bearing material with strong wear resistance at average loads. The plain bearings are self-lubricating and can be used dry. If required the plain bearings can also be lubricated. The material iglidur® M250 is resistant to all common lubricants.

### Mechanical properties

The permissible static surface pressure of iglidur® M250 at room temperature is 20MPa. Due to the possibility of high tolerances in the housing hole, the clip bearing has a high compressive strength even for punched holes.

For bearing surfaces that are very small, the vibration dampening properties and the resistance to edge pressure are especially important.

► iglidur® M250, Page 107

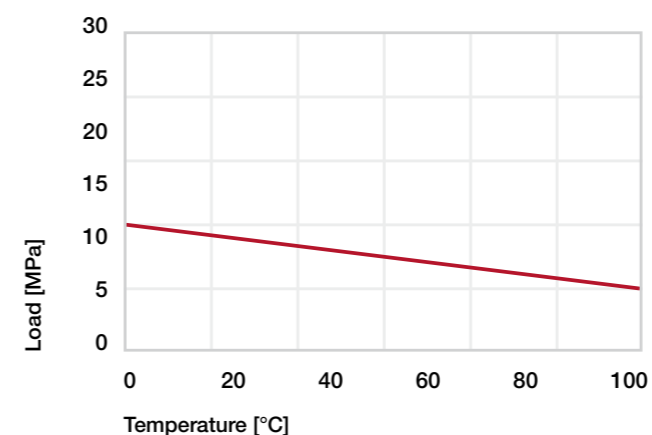

Diagram 01: Maximum recommended surface pressure as a function of temperature (20MPa at +20°C)

### Permissible surface speeds

Clip bearings are extremely wear-resistant in slow rotating, oscillating, and linear movements. The maximum surface speeds for the different movements are the same as for the material iglidur® M250 (table 01).

With lubrication the permissible surface speeds can be increased.

► Surface speed, page 44

m/s	Rotating	Oscillating	Linear
Long-term	0.8	0.6	2.5
Short-term	2	1.4	5

Table 01: Maximum surface speeds

### Temperatures

For operating temperatures up to +80°C iglidur® clip bearings display high wear resistance. Even in the cold, the plain bearings remain elastic and abrasion-resistant.

► Application temperatures, page 49

iglidur® M250	Application temperature
Minimum	-40°C
Max. long-term	+80°C
Maximum, short-term	+170°C

Table 02: Temperature limits

### Assembly

For installation, the plain bearings are pressed together on the side with the large flange. The angled slot makes the bearing spiral shaped so that it can be placed easily into the metal plate. The slot also compensates for expansions of the circumference. In this way, a tight clearance is possible with the clip bearings. The bearing clearance is dimensioned in such a way that in a housing hole with a nominal diameter, a shaft made with the same nominal diameter turns easily. The clip bearings should be fitted into a housing with a "H" class tolerance, up to H13. The clip bearing can also rotate within the housing hole.

Diameter d1 [mm]	Shaft h9 [mm]	Tolerances D11 [mm]	Housing H7 [mm]
up to 3	0-0.025	+0.020 +0.080	0 +0.010
> 3 to 6	0-0.030	+0.030 +0.105	0 +0.012
> 6 to 10	0-0.036	+0.040 +0.130	0 +0.015
> 10 to 18	0-0.043	+0.050 +0.160	0 +0.018
> 18 to 30	0-0.052	+0.065 +0.195	0 +0.021
> 30 to 50	0-0.062	+0.080 +0.240	0 +0.025
> 50 to 80	0-0.074	+0.100 +0.290	0 +0.030

Table 03: Important tolerances for plain bearings according to ISO 3547-1 after press-fit



Image exemplary

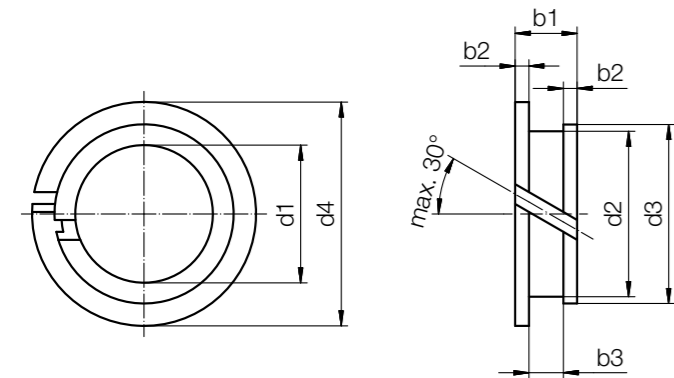

Dimensions [mm]

d1	d2	d3	d4	b1	b2	b3	Part No.
D11 <sup>7)</sup>				+0.20	-0.10		
3	4.2	4.8	6.0	3.2	0.6	2.0	MCM-03-02
3	4.2	4.8	6.0	4.2	0.6	3.0	MCM-03-03
4	5.2	5.9	7.0	3.2	0.6	2.0	MCM-04-02
4	5.2	5.9	7.0	4.2	0.6	3.0	MCM-04-03
5	6.2	6.8	8.0	3.2	0.6	2.0	MCM-05-02
5	6.2	6.8	8.0	4.2	0.6	3.0	MCM-05-03
6	7.2	7.8	11.0	2.7	0.6	1.5	MCM-06-015
6	7.2	7.8	11.0	3.2	0.6	2.0	MCM-06-02
6	7.2	7.8	11.0	4.2	0.6	3.0	MCM-06-03
6	7.2	7.8	11.0	5.2	0.6	4.0	MCM-06-04
7	9.0	9.8	13.0	4.6	0.8	3.0	MCM-07-03
8	9.6	10.4	13.0	3.6	0.8	2.0	MCM-08-02
8	9.6	10.4	13.0	4.6	0.8	3.0	MCM-08-03
8	9.6	13.0	10.4	5.6	0.8	4.0	MCM-08-04
9	10.6	11.4	14.0	3.6	0.8	2.0	MCM-09-02
10	11.6	12.4	15.0	3.6	0.8	2.0	MCM-10-02
10	11.6	12.4	15.0	4.1	0.8	2.5	MCM-10-025
10	11.6	12.4	15.0	4.6	0.8	3.0	MCM-10-03

<sup>7)</sup> d1 value is measured with a plug gauge after fitting into a reference housing d2 (+0.005). Please see D11 tolerances table ► Page 589

Order key

Type Dimensions [mm]

M C M - 03 - 02

- iglidur® material
- Design
- Metric
- Inner Ø d1
- Metal sheet thickness b3

**i** Material:  
iglidur® M250 ► Page 107

**inch** Imperial dimensions available  
► From page 1603

d1	d2	d3	d4	b1	b2	b3	Part No.
D11 <sup>7)</sup>				+0.20	-0.10		
10	11.6	12.4	15	5.6	0.8	4.0	MCM-10-04
10	11.6	12.4	15	9.6	0.8	8.0	MCM-10-08
12	13.6	14.4	17	3.4	0.8	1.8	MCM-12-018
12	13.6	14.4	17	3.6	0.8	2.0	MCM-12-02
12	13.6	14.4	17	4.35	0.8	2.75	MCM-12-025
12	13.6	14.4	17	4.6	0.8	3.0	MCM-12-03
12	13.6	14.4	17	5.1	0.8	3.5	MCM-12-035
12	13.6	14.4	17	5.6	0.8	4.0	MCM-12-04
12	13.6	14.4	17	6.4	0.8	4.8	MCM-12-045
14	15.6	16.4	19	4.6	0.8	3.0	MCM-14-03
16	17.6	18.4	21	3.6	0.8	2.0	MCM-16-02
16	17.6	18.4	21	4.6	0.8	3.0	MCM-16-03
18	20.0	21.0	23	4.0	0.8	2.4	MCM-18-02
18	20.0	21.0	23	5.0	1.0	3.0	MCM-18-03
20	22.0	23.0	25	5.0	1.0	3.0	MCM-20-03
25	27.0	28.0	30	5.0	1.0	3.0	MCM-25-03
25	27.0	28.0	30	8.0	1.0	6.0	MCM-25-06



These clip bearings are made of wear-resistant iglidur® high-performance polymers and are designed specifically for fitting shafts through sheet metal. With this specific clip bearing design, a locating spigot is utilised to enable fitting into less precise holes and housings. The new iglidur® K230 material offers a lower moisture absorption and even more flexibility compared to the iglidur® M250 clip bearings.

**i** Material:  
iglidur® K230 ► Page 1653

- Lubrication and maintenance-free
- Low moisture absorption
- Temperature resistance
- Chemical resistance
- Corrosion resistance

Fitting:



Simple axial press in

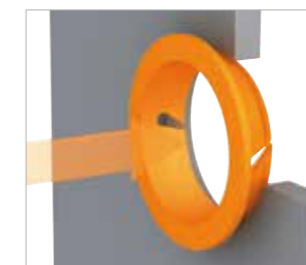

Axial safety through the second flange

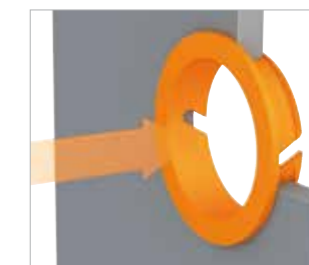

Easy installation via clip on mechanism



Image exemplary

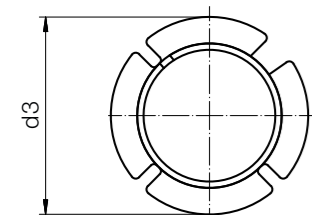
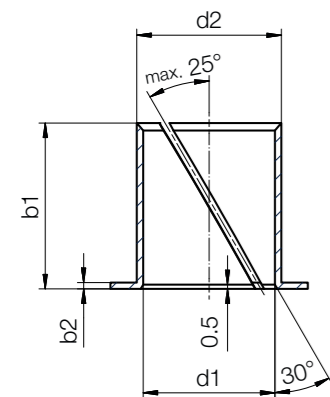

r = max. 0.5mm

Order key

Type	Dimensions [mm]
------	-----------------

**M Y M-04-04**

iglidur® material	<b>Design</b>	Metric	Inner Ø d1	Total length b1
-------------------	---------------	--------	------------	-----------------

**Material:**  
iglidur® M250 ▶ Page 107  
With anti-rotation feature ▶ Page 593

Imperial dimensions available  
▶ From page 1604

Dimensions [mm]

d1	d1 tolerance <sup>7)</sup>	d2 <sup>9)</sup>	d3 ±0.40	b1 -0.40	b2 -0.13	Part No.
4	+0.025 +0.075	5.2	7.0	4.0	0.6	<b>MYM-04-04</b>
5	+0.025 +0.075	6.2	8.0	5.0	0.6	<b>MYM-05-05</b>
6	+0.025 +0.075	7.2	9.5	6.0	0.6	<b>MYM-06-06</b>
8	+0.025 +0.075	9.6	12.0	8.0	0.8	<b>MYM-08-08</b>
10	+0.025 +0.075	11.6	15.0	10.0	0.8	<b>MYM-10-10</b>
12	+0.025 +0.075	13.6	18.0	12.0	0.8	<b>MYM-12-12</b>
14	+0.025 +0.075	15.6	21.0	14.0	0.8	<b>MYM-14-14</b>
16	+0.025 +0.075	17.6	24.0	16.0	0.8	<b>MYM-16-16</b>
20	+0.025 +0.075	21.6	30.0	16.0	0.8	<b>MYM-20-16</b>
20	+0.025 +0.075	21.6	30.0	20.0	0.8	<b>MYM-20-20</b>
25	+0.025 +0.075	27.4	37.5	25.0	1.2	<b>MYM-25-25</b>

<sup>7)</sup> d1 value is measured with a plug gauge after fitting into a reference housing d2 (+0.005)

<sup>9)</sup> Recommended housing hole tolerance: H9



Image exemplary

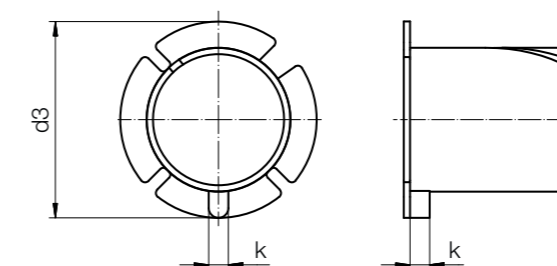
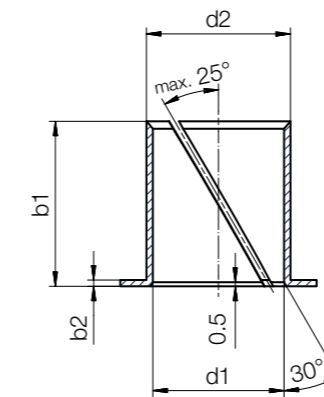

Order key

Type	Dimensions [mm]	Option
------	-----------------	--------

**M Y M- 04 - 04 - K**

iglidur® material	<b>Design</b>	Metric	Inner Ø d1	Total length b1	Anti-rotation feature
-------------------	---------------	--------	------------	-----------------	-----------------------

**Material:**  
iglidur® M250 ▶ Page 107

Imperial dimensions available  
▶ From page 1604

Dimensions [mm]

d1	d1 tolerance <sup>8)</sup>	d2 <sup>9)</sup>	d3 ±0.40	b1 -0.40	b2 -0.13	k	Part No.
4	+0.025 +0.075	5.20	7.00	4.00	0.60	1.0	<b>MYM-04-04-K</b>
5	+0.025 +0.075	6.20	8.00	5.00	0.60	1.0	<b>MYM-05-05-K</b>
6	+0.025 +0.075	7.20	9.50	6.00	0.60	1.5	<b>MYM-06-06-K</b>
10	+0.025 +0.075	11.60	15.00	10.00	0.80	2.0	<b>MYM-10-10-K</b>
14	+0.025 +0.075	15.60	21.00	14.00	0.80	3.0	<b>MYM-14-14-K</b>

<sup>8)</sup> d1 value is measured with a plug gauge after fitting into a reference housing d2 (+0.005)

<sup>9)</sup> Recommended housing hole tolerance: H9



Order key

Type Dimensions [mm]

**M K M-1012-10**

iglidur® material	<b>Design</b>	Metric	Inner Ø d1	Outer Ø d2	Metal sheet thickness
-------------------	---------------	--------	------------	------------	-----------------------

Material:  
iglidur® M250 ▶ Page 107

Sample dimension [mm]

d1	d1 tolerance <sup>3)</sup> E10	d2	d3 d13	b1 h13	b2 h13	b3 +0.1/+0.7	s ±0.1	Part No.
10	+0.025 +0.083	12	18	14	1	10	0.4	<b>MKM-1012-10</b>

<sup>3)</sup> After press-fit. Testing methods ▶ Page 57

Fitting:

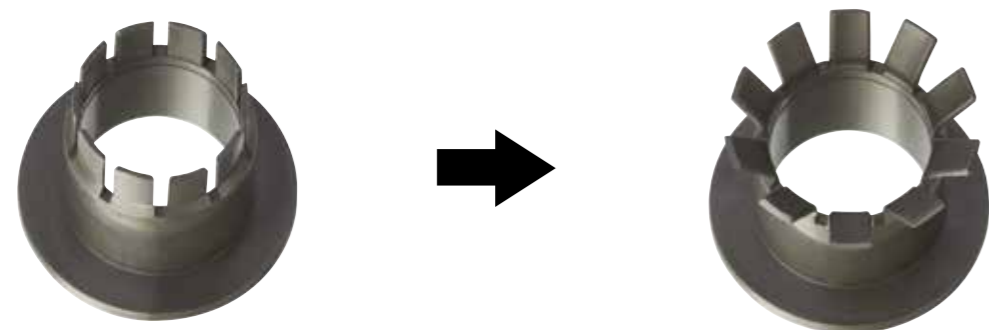

Press in, fold down, ready: captive, axial load on both sides



Please contact us if you need a custom-made double flange bearing for your application. We will help you with your design and create an appropriate proposal, drawing on the experience that we have with a large number of custom bearing solutions.



Order key

Type Dimensions [mm]

**M D M-1213-06**

iglidur® material	<b>Design</b>	Metric	Inner Ø d1	Outer Ø d2	Metal sheet thickness
-------------------	---------------	--------	------------	------------	-----------------------

Material:  
iglidur® M250 ▶ Page 107

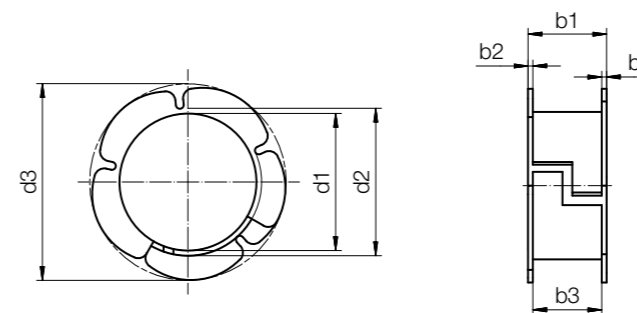

Sample dimension [mm]

d1	d1 tolerance <sup>8)</sup>	d2	d3	b1	b2	b3	Part No.
12	+0.050 +0.160	13	16.5	7	0.5	6.0	<b>MDM-1213-06</b>

<sup>8)</sup> d1 value is measured with a plug gauge after fitting into a reference housing d2 (+0.005)

Fitting:



Please contact us if you need a custom-made double flange bearing for your application. We will help you with your design and create an appropriate proposal, drawing on the experience that we have with a large number of custom bearing solutions.



**The solution for all applications in stamped sheet metal retainers**

iglidur® Clip On are frequently used in seat and convertible top systems and multi-joint hinges. iglidur® Clip On bearings facilitate captive assembly even in punched sheet metal/steering arms with limited fine blanking content.

- Compensation of axial clearance
- Captive pre-assembly possible
- Electrically conductive materials are available
- Pressure-resistant materials up to 80MPa

The Clip On bearings can also be produced from electrically conductive iglidur® RN89, thus permitting e-coating.

**i** Material:  
iglidur® M250 ▶ Page 107  
iglidur® RN89 ▶ Page 1657

**Fitting:**  
The disc is clipped onto the flange bushing with undercuts.



**i** Please contact us if you need this special solution for your application. We will help you with your design and create an appropriate proposal, drawing on the experience that we have with a large number of custom bearing solutions.

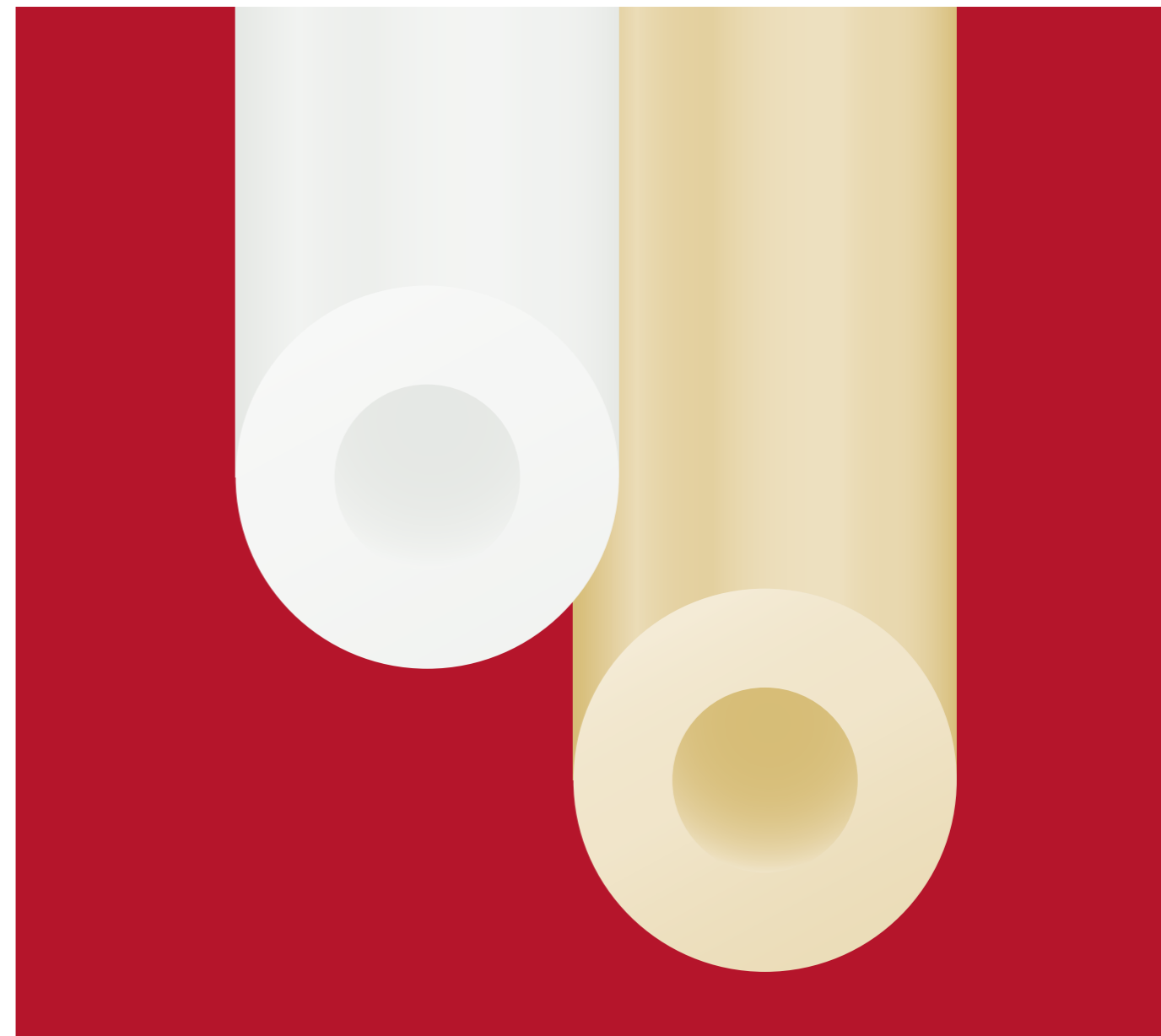

## iglidur® knife edge rollers

- 100% lubrication-free**
- Low drive power**
- Tight deflection radii**
- Long service life of the belt**
- Cost-effective**
- Long service life**
- Standard range from stock**

